

STANDARD COMPONENTS CUSTOMIZED SOLUTIONS

**SPECIALS**  
MATERIALS HANDLING

**FULL AUTOMATIC FUNCTIONS**

**TRANSPORT SYSTEMS**  
**MANIPULATORS**  
**SPECIAL MACHINES**  
**SPECIAL DEVICES**

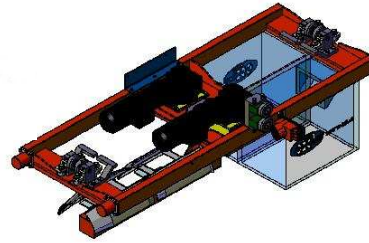

# SPECIALS MATERIALS HANDLING

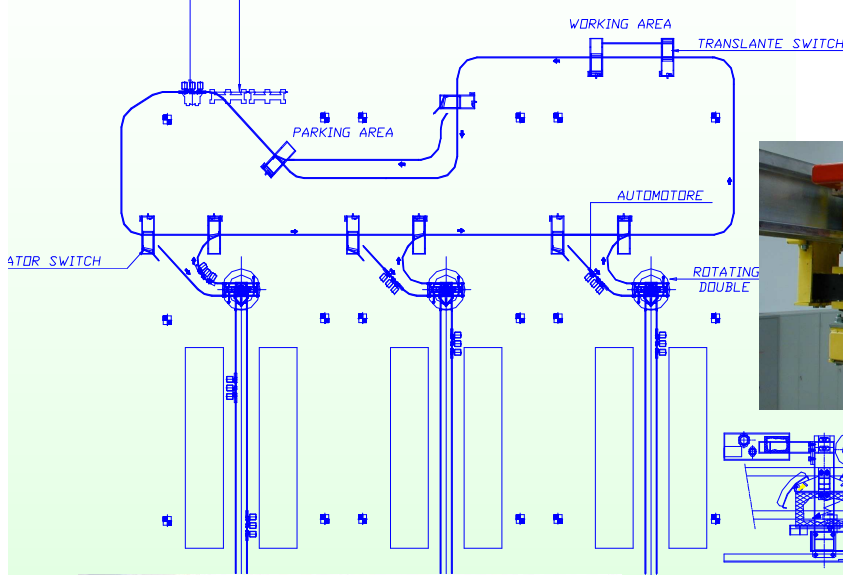

## TRANSPORT SYSTEMS OVERHEAD TRANSPORT SYSTEMS

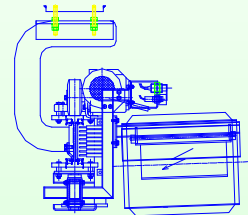
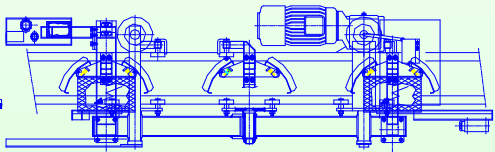

- OVERHEAD CARRIERS
- SWITCHES
- SHIFTERS
- ONE / TWO WAYS TURN TABLES
- LIFTERS





# SPECIALS MATERIALS HANDLING

# WAREHOUSE SYSTEMS

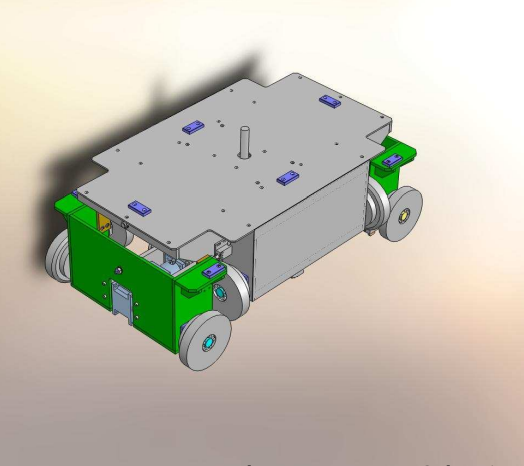
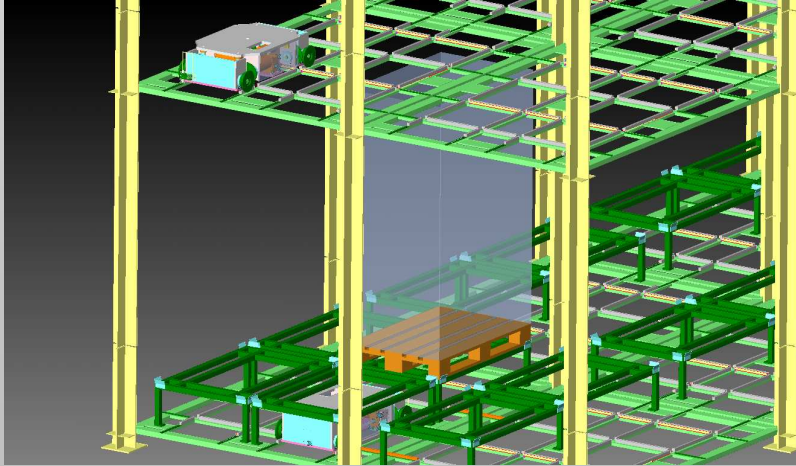
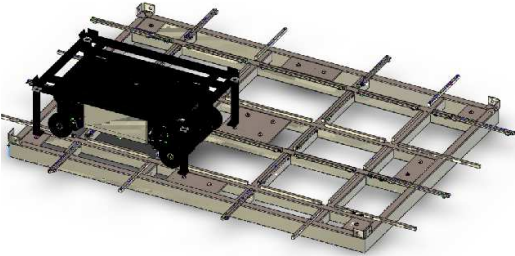
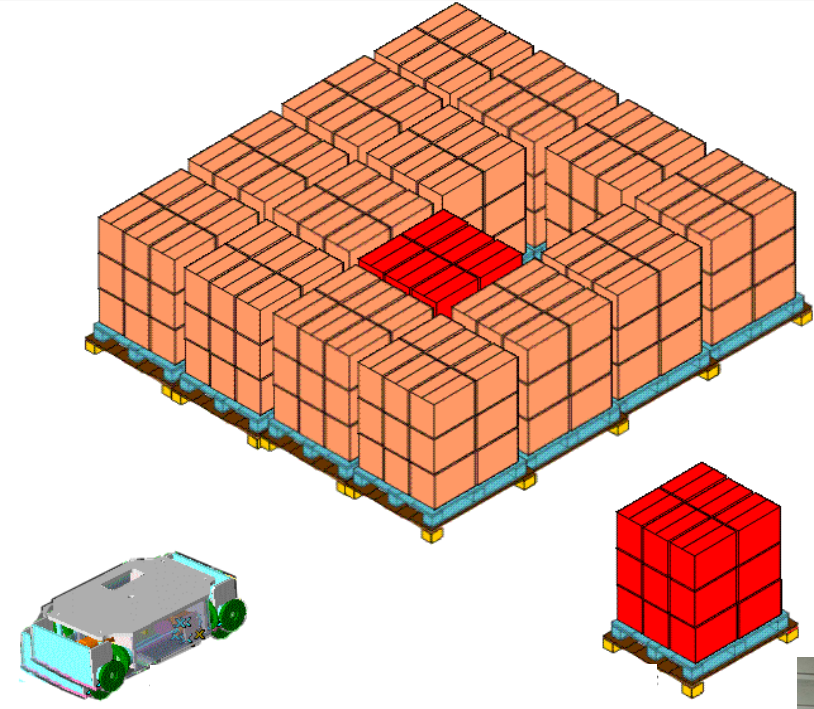



# SPECIALS MATERIALS HANDLING

## TRANSPORT SYSTEMS GROUND TRANSPORT SYSTEMS

- CHAIN , BELT , ROLLER CONVEYORS**
- ROUND BELT CONVEYORS**
- BAND CONVEYORS**
- PLATE , TABLE-TOP CONVEYORS**
- SENDERS , SHIFTERS**
- SHUTTLES**

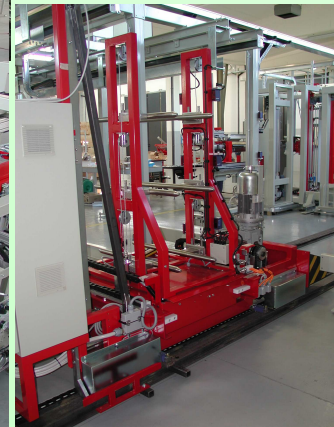
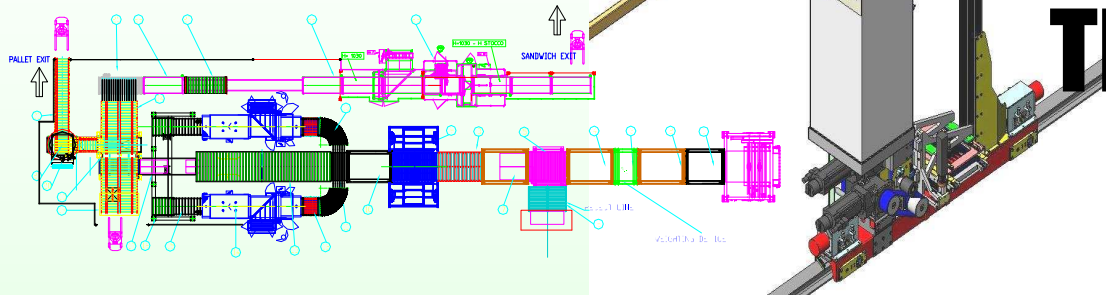



# SPECIALS SPECIAL MACHINES

# MANIPULATORS

- PICK AND PLACE
- POSITIONERS
- GANTRY ROBOTS
- TILTER

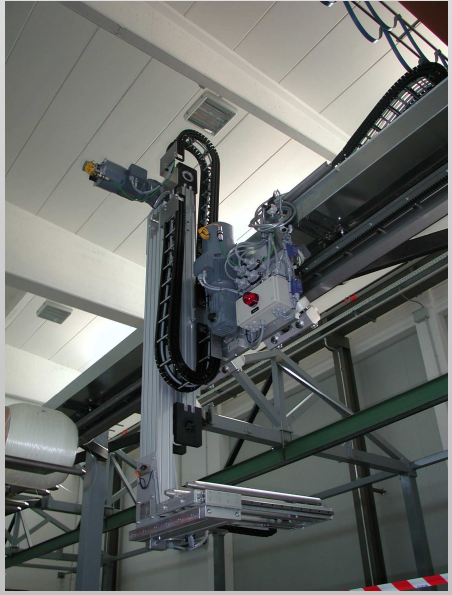
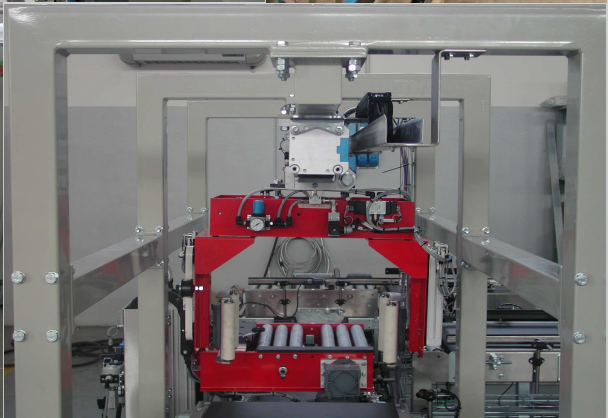
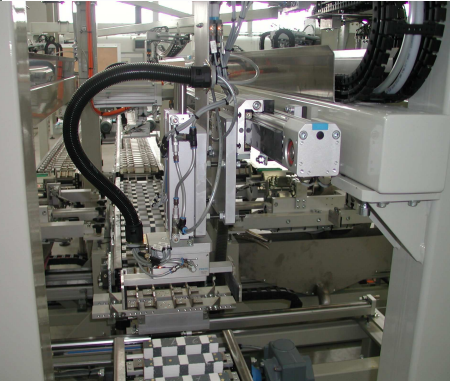
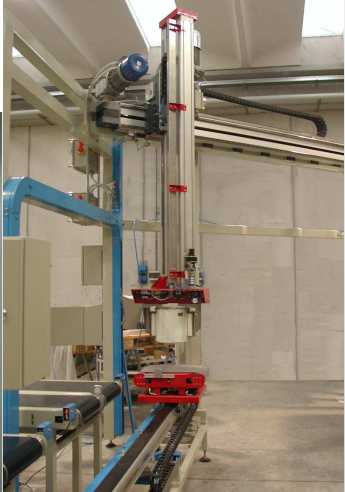
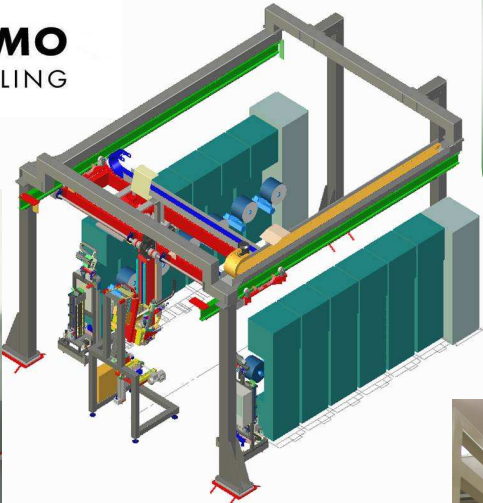
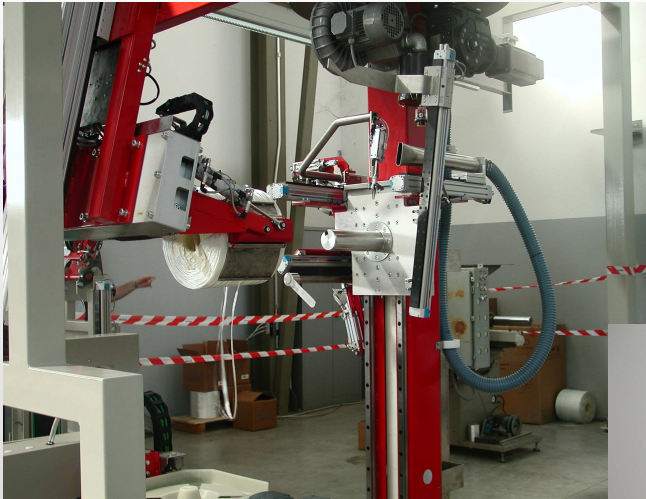



# SPECIALS SPECIAL MACHINES

## SPECIAL MACHINES

- LASER MARKER
- MECHANICAL STRENGTH TESTER
- DISPENSERS
- WEIGHTING SYSTEM
- PRECISE CUTTING CARROUSEL
- COATING MACHINE
- PNEUMATIC AND HYDRAULIC SYSTEM

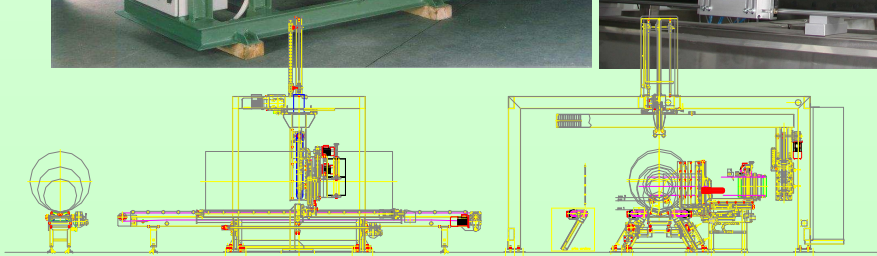
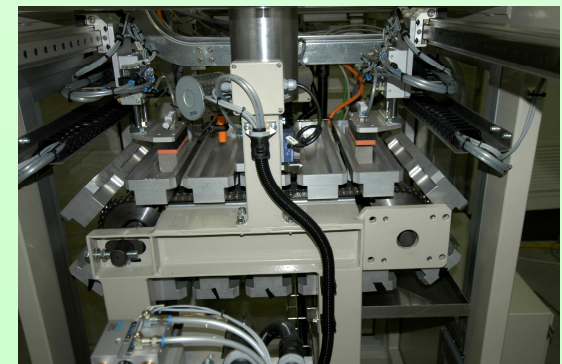
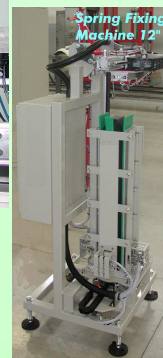
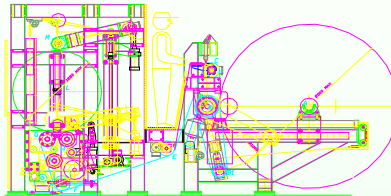



# SPECIALS SPECIAL DEVICES

## HANDLING DEVICES

- VACUUM SYSTEMS
- GRIPPERS
- WEIGHTING SYSTEM
- TELESCOPIC CREDLE
- FOLDERS

